

Small Signal Schottky Diodes, Single & Dual

Features

- These diodes feature very low turn-on voltage and fast switching
- These devices are protected by a PN junction guard ring against excessive voltage, such as electrostatic discharges
- Lead (Pb)-free component
- Component in accordance to RoHS 2002/95/EC and WEEE 2002/96/EC

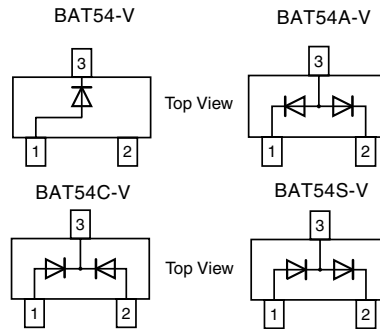
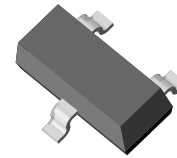

18034

Mechanical Data

Case: SOT23 Plastic case

Weight: approx. 8.8 mg

Packaging Codes/Options:

GS18/10 k per 13" reel (8 mm tape), 10 k/box

GS08/3 k per 7" reel (8 mm tape), 15 k/box

Parts Table

Part	Ordering code	Type Marking	Remarks
BAT54-V	BAT54-V-GS18 or BAT54-V-GS08	L4	Tape and Reel
BAT54A-V	BAT54A-V-GS18 or BAT54A-V-GS08	L42	Tape and Reel
BAT54C-V	BAT54C-V-GS18 or BAT54C-V-GS08	L43	Tape and Reel
BAT54S-V	BAT54S-V-GS18 or BAT54S-V-GS08	L44	Tape and Reel

Absolute Maximum Ratings

T_{amb} = 25 °C, unless otherwise specified

Parameter	Test condition	Symbol	Value	Unit
Repetitive peak reverse voltage		V _{RRM}	30	V
Forward continuous current		I _F	200 ¹⁾	mA
Repetitive peak forward current		I _{FRM}	300 ¹⁾	mA
Surge forward current	t _p < 1 s	I _{FSM}	600 ¹⁾	mA
Power dissipation		P _{tot}	230	mW

¹⁾ Device on fiberglass substrate, see layout on next page.

Vishay Semiconductors

Thermal Characteristics

$T_{amb} = 25\text{ }^{\circ}\text{C}$, unless otherwise specified

Parameter	Test condition	Symbol	Value	Unit
Thermal resistance junction to ambient air		R_{thJA}	430 ¹⁾	K/W
Junction temperature		T_j	125	$^{\circ}\text{C}$
Storage temperature range		T_{stg}	- 65 to + 150	$^{\circ}\text{C}$

¹⁾ Device on fiberglass substrate, see layout on next page.

Electrical Characteristics

$T_{amb} = 25\text{ }^{\circ}\text{C}$, unless otherwise specified

Parameter	Test condition	Symbol	Min	Typ.	Max	Unit
Reverse Breakdown voltage	$I_R = 100\text{ }\mu\text{A}$ (pulsed)	$V_{(BR)}$	30			V
Leakage current	Pulse test $t_p < 300\text{ }\mu\text{s}$, $\delta < 2\%$ at $V_R = 25\text{ V}$	I_R			2	μA
Forward voltage	$I_F = 0.1\text{ mA}$, $t_p < 300\text{ }\mu\text{s}$, $\delta < 2\%$	V_F			240	mV
	$I_F = 1\text{ mA}$, $t_p < 300\text{ }\mu\text{s}$, $\delta < 2\%$	V_F			320	mV
	$I_F = 10\text{ mA}$, $t_p < 300\text{ }\mu\text{s}$, $\delta < 2\%$	V_F			400	mV
	$I_F = 30\text{ mA}$, $t_p < 300\text{ }\mu\text{s}$, $\delta < 2\%$	V_F			500	mV
	$I_F = 100\text{ mA}$, $t_p < 300\text{ }\mu\text{s}$, $\delta < 2\%$	V_F			800	mV
Diode capacitance	$V_R = 1\text{ V}$, $f = 1\text{ MHz}$	C_D			10	pF
Reverse recovery time	$I_F = 10\text{ mA}$ to $I_R = 10\text{ mA}$, $i_R = 1\text{ mA}$, $R_L = 100\text{ }\Omega$	t_{rr}			5	ns

Layout for R_{thJA} test

Thickness:

Fiberglass 1.5 mm (0.059 in.)

Copper leads 0.3 mm (0.012 in.)

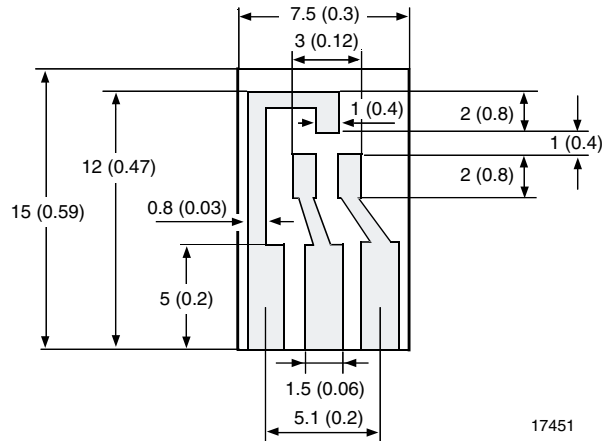

17451

BAT54-V/54A-V/54C-V/54S-V



Vishay Semiconductors

Package Dimensions in mm (Inches): SOT23

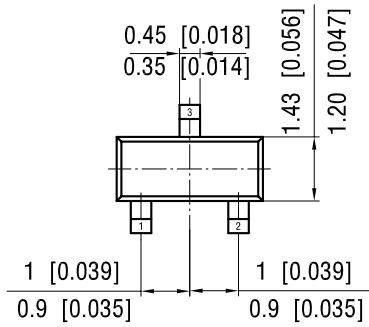
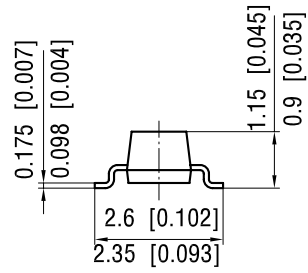
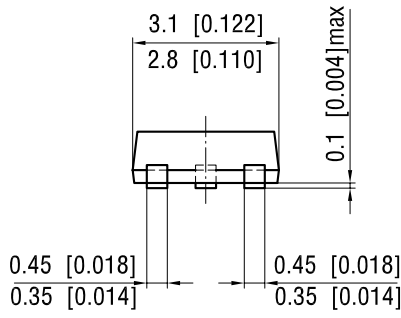

foot print recommendation:

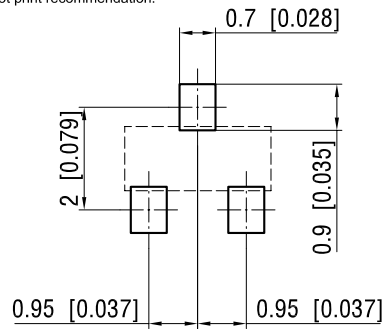

Document no.: 6.541-5014.01-4

Rev. 7 - Date: 08.July.2004

17418